

Product Manual

## Seagate® 600 Pro SSD

### Standard 2.5" Managed Life models

ST480FN0001  
ST400FN0001  
ST240FN0001  
ST200FN0001  
ST120FN0001  
ST100FN0001

### Standard 2.5" Usage Based models

ST480FN0021  
ST400FN0021  
ST240FN0021  
ST200FN0021  
ST120FN0021  
ST100FN0021

## Document Revision History

Revision	Date	Description of changes
Rev. A	03/22/2013	Initial release.

© 2013 Seagate Technology LLC. All rights reserved.

Publication number: 100717897, Rev. A March 2013

Seagate, Seagate Technology and the Wave logo are registered trademarks of Seagate Technology LLC in the United States and/or other countries. Seagate 600 Pro SSD and SeaTools are either trademarks or registered trademarks of Seagate Technology LLC or one of its affiliated companies in the United States and/or other countries. The FIPS logo is a certification mark of NIST, which does not imply product endorsement by NIST, the U.S., or Canadian governments. All other trademarks or registered trademarks are the property of their respective owners.

No part of this publication may be reproduced in any form without written permission of Seagate Technology LLC. Call 877-PUB-TEK1 (877-782-8351) to request permission.

When referring to drive capacity, one gigabyte, or GB, equals one billion bytes and one terabyte, or TB, equals one trillion bytes. Your computer's operating system may use a different standard of measurement and report a lower capacity. In addition, some of the listed capacity is used for formatting and other functions, and thus will not be available for data storage. Actual quantities will vary based on various factors, including file size, file format, features and application software. Actual data rates may vary depending on operating environment and other factors. The export or re-export of hardware or software containing encryption may be regulated by the U.S. Department of Commerce, Bureau of Industry and Security (for more information, visit [www.bis.doc.gov](http://www.bis.doc.gov)), and controlled for import and use outside of the U.S. Seagate reserves the right to change, without notice, product offerings or specifications.

Seagate Technology Support Services .....	1
<hr/>	
<b>1.0 Introduction.....</b>	<b>2</b>
1.1 About the Serial ATA interface .....	2
<hr/>	
<b>2.0 Drive specifications .....</b>	<b>3</b>
2.1 Specification summary tables .....	3
2.2 Formatted capacity .....	4
2.2.1 LBA mode .....	4
2.3 Default logical geometry for ATA based systems .....	4
2.4 Performance, Recording and interface technology.....	5
2.4.1 Interface technology .....	5
2.4.2 Recording technology .....	5
2.4.3 Performance.....	5
2.5 Physical characteristics .....	6
2.6 Access time .....	6
2.7 Time to Ready .....	6
2.8 Power specifications .....	7
2.8.1 Power consumption.....	7
2.8.2 DC power requirements.....	7
2.9 Environmental specifications.....	14
2.9.1 Temperature .....	14
2.9.2 Temperature gradient.....	14
2.9.3 Humidity.....	14
2.9.4 Altitude.....	14
2.9.5 Shock.....	14
2.9.6 Vibration.....	14
2.10 Electromagnetic immunity.....	15
2.11 Reliability.....	16
2.11.1 Annualized Failure Rate (AFR) and Mean Time Between Failures (MTBF).....	16
2.11.2 Reliability specifications.....	16
2.12 Agency certification.....	17
2.12.1 Safety certification.....	17
2.12.2 Electromagnetic compatibility .....	17
2.12.3 FCC verification .....	17
2.13 Environmental protection .....	18
2.13.1 European Union Restriction of Hazardous Substances (RoHS) Directive.....	18
2.13.2 China Restriction of Hazardous Substances (RoHS) Directive .....	18
2.14 Corrosive environment .....	18
<hr/>	
<b>3.0 Configuring and mounting the drive.....</b>	<b>19</b>
3.1 Handling and static-discharge precautions.....	19
3.2 Configuring the drive .....	19
3.3 Serial ATA cables and connectors .....	19
3.4 Drive mounting .....	20
3.5 Cooling .....	21
<hr/>	
<b>4.0 Serial ATA (SATA) interface .....</b>	<b>22</b>
4.1 Hot-Plug compatibility.....	22
4.2 Serial ATA device plug connector pin definitions .....	22
4.3 Supported ATA commands.....	24
4.3.1 Identify Device command .....	26
4.3.2 Set Features command .....	32
4.3.3 S.M.A.R.T. commands.....	33
4.3.4 SSD Percentage Endurance Remaining Indicator .....	33

Figure 1.	Typical 5V Startup and Operation Current Profile .....	13
Figure 2.	Attaching SATA cabling .....	19
Figure 3.	Mounting configuration dimensions (7mm models) .....	20
Figure 4.	Air flow .....	21

# Seagate Technology Support Services

For information regarding online support and services, visit <http://www.seagate.com/about/contact-us/technical-support/>

Available services include:

- Presales & Technical support
- Global Support Services telephone numbers & business hours
- Authorized Service Centers

Warranty terms will vary based on type of warranty chosen: “Managed Life” or “Usage Based”. Consult your Seagate sales representative for warranty terms and conditions.

For information regarding data recovery services, visit <http://www.seagate.com/services-software/data-recovery-services/>

For Seagate OEM and Distribution partner portal, visit: <http://www.seagate.com/partners/>

For Seagate reseller portal, visit: <http://www.seagate.com/partners/my-spp-dashboard/>

## 1.0 INTRODUCTION

This manual describes the functional, mechanical and interface specifications for the following Seagate® 600 Pro SSD model drives:

2.5" MANAGED LIFE MODEL	2.5" USAGE BASED MODEL
ST480FN0001	ST480FN0021
ST400FN0001	ST400FN0021
ST240FN0001	ST240FN0021
ST200FN0001	ST200FN0021
ST120FN0001	ST120FN0021
ST100FN0001	ST100FN0021

These drives provide the following key features:

- Multi-Level Cell (MLC) NAND Flash storage.
- Serial ATA 3.1 Host Interface (SATA 6Gb/s).
- High instantaneous (burst) data-transfer rates (up to 520MB/s).
- Parallel flash access channels.
- State-of-the-art on-the-fly error-correction algorithms.
- Native Command Queueing with command ordering to increase performance in demanding applications.
- Highly integrated hardware functions.
- Power loss data protection.
- Data Set Management with Trim Support.
- Silent operation.
- SeaTools diagnostic software performs a drive self-test that eliminates unnecessary drive returns.
- Support for S.M.A.R.T. drive monitoring and reporting.
- Supports latching SATA cables and connectors.
- Worldwide Name (WWN) capability uniquely identifies the drive.

### 1.1 ABOUT THE SERIAL ATA INTERFACE

The Serial ATA interface provides several advantages:

- Easy installation and configuration with true plug-and-play connectivity. It is not necessary to set any jumpers or other configuration options.
- Thinner and more flexible cabling for improved enclosure airflow and ease of installation.
- Scalability to higher performance levels.

The Serial ATA interface connects each drive in a point-to-point configuration with the Serial ATA host adapter. If two drives are attached on one Serial ATA host adapter, the host operating system views the two devices as if they were both “masters” on two separate ports.

**Note.** The host adapter may, optionally, emulate a master/slave environment to host software where two devices on separate Serial ATA ports are represented to host software as a Device 0 (master) and Device 1 (slave) accessed at the same set of host bus addresses. A host adapter that emulates a master/slave environment manages two sets of shadow registers. This is not a typical Serial ATA environment.

The Serial ATA host adapter and drive share the function of emulating parallel ATA device behavior to provide backward compatibility with existing host systems and software. The Command and Control Block registers, PIO and DMA data transfers, resets, and interrupts are all emulated.

The Serial ATA host adapter contains a set of registers that shadow the contents of the traditional device registers, referred to as the Shadow Register Block. All Serial ATA devices behave like Device 0 devices. For additional information about how Serial ATA emulates parallel ATA, refer to the “Serial ATA: High Speed Serialized AT Attachment” specification. The specification can be downloaded from [www.serialata.org](http://www.serialata.org).

## 2.0 DRIVE SPECIFICATIONS

Unless otherwise noted, all specifications are measured under ambient conditions, at 25°C, and nominal power. For convenience, the phrases *the drive* and *this drive* are used throughout this manual to indicate the following drive models:

	Capacity					
	480GB	400Gb	240GB	200GB	120GB	100GB
<b>2.5" Managed Life Warranty</b>	ST480FN0001	ST400FN0001	ST240FN0001	ST200FN0001	ST120FN0001	ST100FN0001
<b>2.5" Usage Based Warranty</b>	ST480FN0021	ST400FN0021	ST240FN0021	ST200FN0021	ST120FN0021	ST100FN0021

Product data communicated in this manual is specific only to the model numbers listed in this manual. The data listed in this manual may not be predictive of future generation specifications or requirements. If you are designing a system which will use one of the models listed or future generation products and need further assistance, please contact your Customer Technical Support Engineer or our global support services group as shown in See “Seagate Technology Support Services” on page 1.

## 2.1 SPECIFICATION SUMMARY TABLES

The specifications listed in the following table is for quick reference. For details on specification measurement or definition, see the appropriate section of this manual.

**Table 1 Drive specifications summary for 2.5" - 400, 200 and 100 GB models**

Drive specification	ST480FN0001 ST480FN0021	ST400FN0001 ST400FN0021	ST240FN0001 ST240FN0021	ST200FN0001 ST200FN0021	ST120FN0001 ST120FN0021	ST100FN0001 ST100FN0021
Formatted GB (512 bytes/sector) <sup>[1]</sup>	480	400	240	200	120	100
Guaranteed logical block addresses (LBAs)	937,703,088	781,422,768	468,862,128	390,721,968	234,441,648	195,371,568
Emulated Bytes per LBA	512					
Peak 128KB sequential read/write data transfer rate (MB/s max)	520/400				520/300	
Sustained 128KB sequential read/write data transfer rate (MB/s max)	520/400				520/300	
Peak 4KB Random read/write command rate (KIOPs)	85/30				80/20	
Sustained 4KB Random read/write command rate (KIOPs)	85/11	85/30	85/11	85/30	80/8	80/20
Flash Memory Type	NAND MLC					
I/O data-transfer rate (MB/s max)	600					
Height (mm max)	7.00 mm (0.276 in)					
Width (mm max)	70.10 mm (2.760 in)					
Length (mm max)	100.45 mm (3.955 in)					
Weight (max)	100 g (0.220 lb)					
Power-on to ready (sec typ) <sup>[2]</sup>	3 sec					
Standby to ready (sec max)	3 sec					
Average LBA access time (µs typ)	~158 µs read; ~125 µs write					
Data Retention (typical minimum at 40°C)	3 months					
Sustainable Write Bandwidth under JEDEC Mix for 3 Year Endurance at 100% duty cycle in MB/sec	2.5	9.7	1.3	4.8	0.6	2.4
Startup current 5V (typical/peak)	550 / 600 mA					
Voltage tolerance (including noise)	5V ± 5%					
Temperature	0° to 70°C (operating as reported by SMART attribute 194) -40° to 75°C (nonoperating)					
Temperature gradient (°C per hour max)	20°C (operating) 20°C (nonoperating)					
Relative humidity	5% to 95% (operating) 5% to 95% (nonoperating)					
Relative humidity gradient	20% per hour max					

Drive specification	ST480FN0001 ST480FN0021	ST400FN0001 ST400FN0021	ST240FN0001 ST240FN0021	ST200FN0001 ST200FN0021	ST120FN0001 ST120FN0021	ST100FN0001 ST100FN0021
Wet bulb temperature (°C max)	29					
Altitude, operating	-61 m to 3048 m (-200 ft. to 10,000+ ft.)					
Altitude, nonoperating (below mean sea level, max)	-61 m to 12,192 m (-200 ft to 40,000+ ft)					
Operational Shock (max at 0.5ms)	1000 Gs					
Non-Operational Shock (max at 0.5ms)	1000 Gs					
Vibration, random operating	20–2000 Hz: 11.08 Grms					
Vibration, random nonoperating	20–2000 Hz: 11.08 Grms					
Nonrecoverable read errors, max	1 LBA per 10 <sup>16</sup> bits read					
Annualized Failure Rate (AFR)	0.58%					
Warranty 3 <sup>[3]</sup>	5 Year Usage Based or 3 Year Life Managed configuration					
Lifetime Power cycles	25,000					
Supports Hotplug operation per Serial ATA Revision 3.0 specification	Yes					

[1] One GB equals one billion bytes when referring to drive capacity. Accessible capacity may vary depending on operating environment and formatting.

[2] Max time approximately 30 sec when standby immediate was not issued before power down.

[3] Warranty terms will vary based on type of warranty chosen: "Managed Life" or "Usage Based".  
Consult your Seagate sales representative for warranty terms and conditions.

## 2.2 FORMATTED CAPACITY

Formatted capacity*	Guaranteed LBAs	Emulated LBA Size (Bytes)
480GB	937,703,088	512
400GB	781,422,768	
240GB	468,862,128	
200GB	390,721,968	
120GB	234,441,648	
100GB	195,371,568	

\*One GB equals one billion bytes when referring to drive capacity. Accessible capacity may vary depending on operating environment and formatting.

### 2.2.1 LBA mode

When addressing these drives in LBA mode, all blocks (LBAs) are consecutively numbered from 0 to  $n-1$ , where  $n$  is the number of guaranteed LBAs as defined above.

See Section 4.3.1, "Identify Device command" (words 60-61 and 100-103) for additional information about 48-bit addressing support of drives with capacities over 137GB.

## 2.3 DEFAULT LOGICAL GEOMETRY FOR ATA BASED SYSTEMS

CYLINDERS	READ/WRITE HEADS	SECTORS PER TRACK
16,383	16	63



## 2.4 PERFORMANCE, RECORDING AND INTERFACE TECHNOLOGY

### 2.4.1 Interface technology

	480GB MODELS	400GB MODELS	240GB MODELS	200GB MODELS	120GB MODELS	100GB MODELS
Interface	Serial ATA (SATA-II)					
Interface Speeds Supported	6Gb/s, 3Gb/s, 1.5Gb/s					
Maximum Burst Transfer Rate	600MB/s					
Hot Plug Support	Yes					
Native Command Queuing Support	Yes					
Trim Support	Yes					
Lifetime Endurance Management Option	Yes					

### 2.4.2 Recording technology

Flash Memory Type	NAND MLC
Emulated LBA Size (Bytes)	512
Native Programmable Page size (User Bytes)	8192
Default transfer alignment offset	0
Typical Data Retention with Power removed (at 40°C)	3 months

### 2.4.3 Performance

	Notes	480GB	400GB	240GB	200GB	120GB	100GB
Maximum Burst Transfer Rate (MB/s)		520					
Peak sequential 128KB read/write data transfer rate (MB/s max)	[4]	520/400				520/300	
Sustained sequential 128KB read/write data transfer rate (MB/s)	[4]	520/400				520/300	
Peak 4KB random read/write command rate (KIOPs)	[5]	85/30				80/20	
Sustained 4KB random read/write command rate (KIOPs)	[5]	85/11	85/30	85/11	85/30	85/8	85/20

[4] Testing performed at Queue Depth = 32, Sequentially Preconditioned drive, using IOMeter 2006.7.27.

[5] Testing performed at Queue Depth = 32, Randomly Preconditioned drive, using IOMeter 2006.7.27.

[6] Testing performed at Queue Depth = 32, Non-Preconditioned drive, using IOMeter 2006.7.27.

**Note.** IOMeter is available at <http://www.iometer.org/> or <http://sourceforge.net/projects/iometer/>. IOMeter is licensed under the Intel Open Source License and the GNU General Public License. Intel does not endorse any IOMeter results.

Peak performance is defined as the typical best case performance that the product will be able to achieve when the product is preconditioned as mentioned and host commands are aligned on 4KB boundaries.

Sustained performance is defined as the typical worst case performance that the product will be able to achieve when the product is preconditioned as mentioned and host commands are aligned on 4KB boundaries. For models that support Lifetime Endurance Management, write values also take into account the worst case performance throttling that may occur to ensure the product meets specified reliability specifications.

Due to the nature of Flash memory technologies there are many factors that can result in values different than those stated in this specification. Some discrepancies can be caused by bandwidth limitations in the host adapter, operating system, or driver limitations. It is not the intent of this manual to cover all possible causes of performance discrepancies.

When evaluating performance of SSD devices, it is recommended to measure performance of the device in a method that resembles the targeted application using real world data and workloads. Test time should also be adequately large to ensure that sustainable metrics and measures are obtained.

## 2.5 PHYSICAL CHARACTERISTICS

	2.5" models
Maximum height	7.00 mm (0.276 in)
Maximum width	70.10 mm (2.760 in)
Maximum length	100.45 mm (3.955 in)
Max weight	100 g (0.220 lb)

## 2.6 ACCESS TIME

Access measurements are taken with nominal power at 25°C ambient temperature. All times are measured using drive diagnostics. The specifications in the table below are defined as follows:

- Page-to-page access time is an average of all possible page-to-page accesses in both directions for a sequentially preconditioned drive.
- Average access time is a true statistical random average of at least 5000 measurements of accesses between programmable pages, less overhead, on a randomly preconditioned drive.

*TYPICAL ACCESS TIMES (µs)	READ	WRITE
Average	158	125

**Note.** These drives are designed to provide the highest possible performance under typical conditions. However, due to the nature of Flash memory technologies there are many factors that can result in values different than those stated in this specification.

## 2.7 TIME TO READY

	480GB 400GB	240GB 200GB	120GB 100GB
Power-on to Ready for non-Media related Commands (sec)	3 (typ)		
Power-on to Ready for Media related commands (sec)	14 (max)		
Standby to Ready (sec)	3 (max)		
Ready to power removal (sec)	3 (max)		

Power-on to Ready for non-media related commands is defined as the time that it will take the drive to respond from the application power until it is ready to accept commands from the host that do not require access to the flash media. In some cases the drive may accept media access commands during this time, but the commands will not be completed or status returned to the host until the media can be accessed safely. Commands such as Check Power and Identify are examples of non-media related commands.

Power-on to Ready for media related commands is defined as the time that it will take the drive to respond from the application power until it is ready to accept commands from the host that require access to the flash media. Commands such as FPDMA Read Extended and FPDMA Write Extended are examples of media related commands. This value includes the time needed to charge the Power Loss Data Protection Circuit to a level that is adequate to protect customer data from unexpected power loss.

The maximum time for Power-on to Ready is dependent on if a STANDBY IMMEDIATE was issued prior to power down and the write workload profile prior to power down.

## 2.8 POWER SPECIFICATIONS

The drive receives DC power (+5V) through a native SATA power connector. See Figure 2 on page 19.

### 2.8.1 Power consumption

Power requirements for the drives are listed in the table on page 9. Typical power measurements are based on an average of drives tested, under nominal conditions, at 35°C ambient temperature.

- **Startup power**

Startup power is measured from the time of power-on to the time that the drive reaches operating condition and can process media access commands.

- **Peak operating mode**

During peak operating mode, the drive is tested in various read and write access patterns to simulate the worst-case power consumption.

- **Idle mode power**

Idle mode power is measured with the drive powered up and ready for media access commands, with no media access commands having been received from the host.

- **Standby mode**

During Standby mode, the drive accepts commands, but not be able to immediately access the media because the drive electronics are in a partial power-down mode.

### 2.8.2 DC power requirements

**Table 2 480GB DC power requirements**

Parameter	ST480FN00x1 (6.0Gb)	
	+5V	Power
Regulation	+/- 5%	(watts)
Average Idle Current	0.46	2.29
Average Sleep Current	0.10	0.50
Maximum Start Current		
DC (Peak DC)	0.58	
AC (Peak AC)	0.56	
Delayed Motor Start (DC max)	0.11	
Peak Operating Current (random read):		
Typical DC	0.34	1.72
Maximum DC	0.36	1.79
Maximum DC (peak)	0.96	
Peak Operating Current (random write):		
Typical DC	0.36	1.79
Maximum DC	0.37	1.84
Maximum DC (peak)	1.56	
Peak Operating Current (sequential read):		
Typical DC	0.46	2.30
Maximum DC	0.47	2.35
Maximum DC (peak)	0.96	
Peak Operating Current (sequential write):		
Typical DC	0.48	2.39
Maximum DC	0.49	2.45
Maximum DC (peak)	1.78	

\*During periods of drive idle, some offline activity may occur according to the S.M.A.R.T. specification, which may increase power to operational levels.

**Table 3 400GB DC power requirements**

Parameter	ST400FN00x1 (6.0Gb)	
	+5V	Power
Regulation	+/- 5%	(watts)
Average Idle Current	0.46	2.30
Average Sleep Current	0.10	0.50
Maximum Start Current		
DC (Peak DC)	0.58	
AC (Peak AC)	0.58	
Delayed Motor Start (DC max)	0.11	
Peak Operating Current (random read):		
Typical DC	0.35	1.73
Maximum DC	0.36	1.79
Maximum DC (peak)	0.96	
Peak Operating Current (random write):		
Typical DC	0.37	1.83
Maximum DC	0.38	1.92
Maximum DC (peak)	1.56	
Peak Operating Current (sequential read):		
Typical DC	0.46	2.30
Maximum DC	0.47	2.35
Maximum DC (peak)	0.94	
Peak Operating Current (sequential write):		
Typical DC	0.48	2.39
Maximum DC	0.49	2.45
Maximum DC (peak)	1.22	

\*During periods of drive idle, some offline activity may occur according to the S.M.A.R.T. specification, which may increase power to operational levels.

**Table 4 240GB DC power requirements**

Parameter	ST240FN00x1 (6.0Gb)	
	+5V	Power
Regulation	+/- 5%	(watts)
Average Idle Current	0.42	2.08
Average Sleep Current	0.10	0.50
Maximum Start Current		
DC (Peak DC)	0.55	
AC (Peak AC)	0.58	
Delayed Motor Start (DC max)	0.11	
Peak Operating Current (random read):		
Typical DC	0.32	1.59
Maximum DC	0.33	1.67
Maximum DC (peak)	0.92	
Peak Operating Current (random write):		
Typical DC	0.33	1.65
Maximum DC	0.34	1.71
Maximum DC (peak)	1.32	
Peak Operating Current (sequential read):		
Typical DC	0.43	2.17
Maximum DC	0.44	2.22
Maximum DC (peak)	0.92	
Peak Operating Current (sequential write):		
Typical DC	0.54	2.71
Maximum DC	0.56	2.81
Maximum DC (peak)	1.26	

\*During periods of drive idle, some offline activity may occur according to the S.M.A.R.T. specification, which may increase power to operational levels.

**Table 5 200GB DC power requirements**

Parameter	ST200FN00x1 (6.0Gb)	
	+5V	Power
<b>Regulation</b>	<b>+/- 5%</b>	<b>(watts)</b>
Average Idle Current	0.42	2.10
Average Sleep Current	0.10	0.50
Maximum Start Current		
DC (Peak DC)	0.54	
AC (Peak AC)	0.58	
Delayed Motor Start (DC max)	0.11	
Peak Operating Current (random read):		
Typical DC	0.32	1.61
Maximum DC	0.34	1.68
Maximum DC (peak)	0.90	
Peak Operating Current (random write):		
Typical DC	0.34	1.69
Maximum DC	0.35	1.73
Maximum DC (peak)	1.30	
Peak Operating Current (sequential read):		
Typical DC	0.44	2.20
Maximum DC	0.45	2.24
Maximum DC (peak)	0.96	
Peak Operating Current (sequential write):		
Typical DC	0.47	2.36
Maximum DC	0.48	2.41
Maximum DC (peak)	1.16	

\*During periods of drive idle, some offline activity may occur according to the S.M.A.R.T. specification, which may increase power to operational levels.

**Table 6 120GB DC power requirements**

Parameter	ST120FN00x1 (6.0Gb)	
	+5V	Power
Regulation	+/- 5%	(watts)
Average Idle Current	0.41	2.07
Average Sleep Current	0.09	0.46
Maximum Start Current		
DC (Peak DC)	0.49	
AC (Peak AC)	0.88	
Delayed Motor Start (DC max)	0.09	
Peak Operating Current (random read):		
Typical DC	0.33	1.63
Maximum DC	0.35	1.73
Maximum DC (peak)	0.94	
Peak Operating Current (random write):		
Typical DC	0.51	2.53
Maximum DC	0.52	2.58
Maximum DC (peak)	1.18	
Peak Operating Current (sequential read):		
Typical DC	0.47	2.36
Maximum DC	0.48	2.42
Maximum DC (peak)	0.96	
Peak Operating Current (sequential write):		
Typical DC	0.54	2.70
Maximum DC	0.55	2.77
Maximum DC (peak)	1.16	

\*During periods of drive idle, some offline activity may occur according to the S.M.A.R.T. specification, which may increase power to operational levels.

**Table 7 100GB DC power requirements**

Parameter	ST100FN00x1 (6.0Gb)	
	+5V	Power
Regulation	+/- 5%	(watts)
Average Idle Current	0.42	2.10
Average Sleep Current	0.09	0.46
Maximum Start Current		
DC (Peak DC)	0.49	
AC (Peak AC)	0.86	
Delayed Motor Start (DC max)	0.09	
Peak Operating Current (random read):		
Typical DC	0.33	1.64
Maximum DC	0.34	1.71
Maximum DC (peak)	0.92	
Peak Operating Current (random write):		
Typical DC	0.34	1.72
Maximum DC	0.36	1.78
Maximum DC (peak)	1.14	
Peak Operating Current (sequential read):		
Typical DC	0.45	2.25
Maximum DC	0.46	2.29
Maximum DC (peak)	0.94	
Peak Operating Current (sequential write):		
Typical DC	0.52	2.61
Maximum DC	0.53	2.67
Maximum DC (peak)	1.10	

\*During periods of drive idle, some offline activity may occur according to the S.M.A.R.T. specification, which may increase power to operational levels.



### 2.8.2.1 Typical current profiles

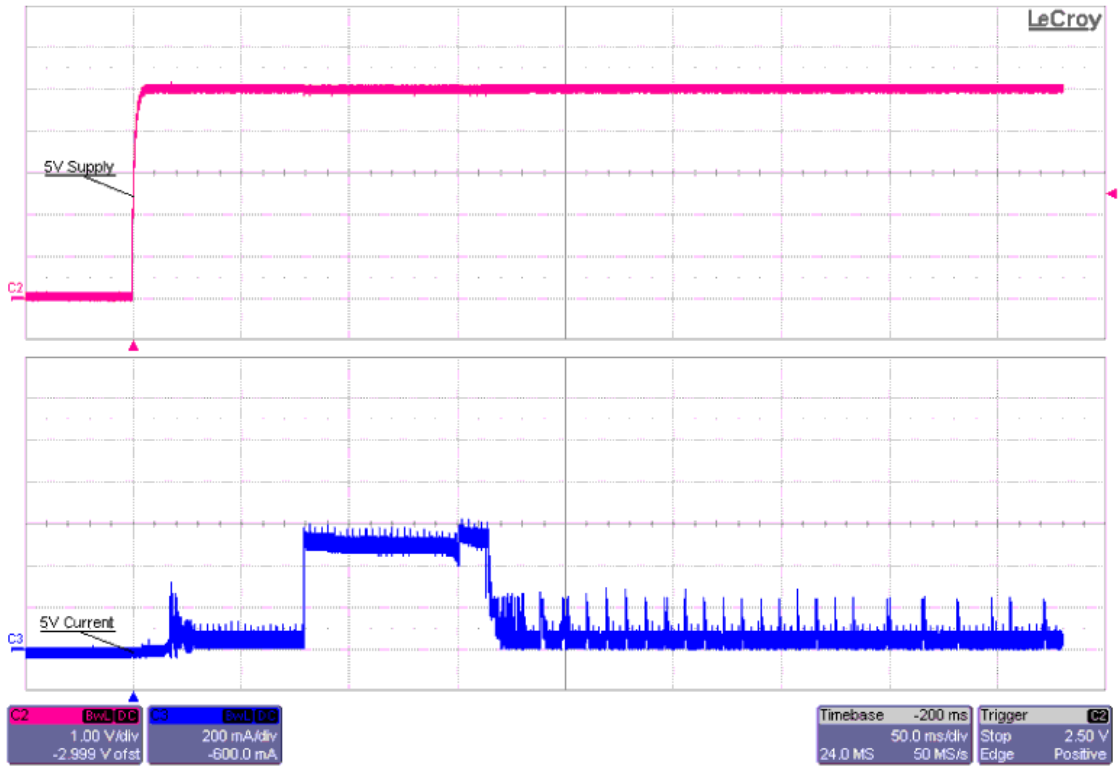

Figure 1. Typical 5V Startup and Operation Current Profile

## 2.9 ENVIRONMENTAL SPECIFICATIONS

### 2.9.1 Temperature

Temperature is defined as the drive's internal temperature as reported by SMART attribute 194 for operation or the drive case temperature for non-operating.

Above 1000 feet (305 meters), the maximum temperature is derated linearly to 112°F (44°C) at 10,000 feet (3048 meters).

Operating:	0° to 70°C (32° to 158°F)
Nonoperating:	−40° to 75°C (−40° to 167°F)

### 2.9.2 Temperature gradient

Operating:	20°C per hour (30°F per hour max), without condensation
Nonoperating:	20°C per hour (30°F per hour max)

### 2.9.3 Humidity

#### 2.9.3.1 Relative humidity

Operating:	5% to 95% noncondensing (20% per hour max)
Nonoperating:	5% to 95% noncondensing (20% per hour max)

#### 2.9.3.2 Wet bulb temperature

Operating:	29°C (84°F max)
Nonoperating:	29°C (84°F max)

### 2.9.4 Altitude

** Operating:	−61 m to 3048 m (−200 ft. to 10,000+ ft.)
** Nonoperating:	−61 m to 12,192 m (−200 ft. to 40,000+ ft.)

\*\* Applies to atmospheric pressure only.

### 2.9.5 Shock

All shock specifications assume that the drive is mounted securely with the input shock applied at the drive mounting screws. Shock may be applied in the X, Y or Z axis.

#### 2.9.5.1 Operating shock

These drives comply with the performance levels specified in this document when subjected to a maximum operating shock of 1000 Gs based on half-sine shock pulses of 0.5ms. This specification does not cover connection issues that may result from testing at this level.

#### 2.9.5.2 Nonoperating shock

The nonoperating shock level that the drive can experience without incurring physical damage or degradation in performance when subsequently put into operation is 1000 Gs based on a half-sine shock pulse of 0.5ms duration.

### 2.9.6 Vibration

All vibration specifications assume that the drive is mounted securely with the input vibration applied at the drive mounting screws. Vibration may be applied in the X, Y or Z axis.

### 2.9.6.1 Operating vibration

The maximum random vibration levels that the drive may experience while meeting the performance standards specified in this document are specified below. This specification does not cover connection issues that may result from testing at this level.

20–2000 Hz	11.08 Grms
------------	------------

### 2.9.6.2 Nonoperating vibration

The maximum random nonoperating vibration levels that the drive may experience without incurring physical damage or degradation in performance when subsequently put into operation are specified below.

20–2000 Hz	11.08 Grms
------------	------------

## 2.10 ELECTROMAGNETIC IMMUNITY

When properly installed in a representative host system, the drive operates without errors or degradation in performance when subjected to the radio frequency (RF) environments defined in the following table:

**Table 8** *Radio frequency environments*

TEST	DESCRIPTION	PERFORMANCE LEVEL	REFERENCE STANDARD
Electrostatic discharge	Contact, HCP, VCP: $\pm 4$ kV; Air: $\pm 8$ kV	B	EN 61000-4-2: 95
Radiated RF immunity	80 to 1000 MHz, 3 V/m, 80% AM with 1 kHz sine 900 MHz, 3 V/m, 50% pulse modulation @ 200 Hz	A	EN 61000-4-3: 96 ENV 50204: 95
Electrical fast transient	$\pm 1$ kV on AC mains, $\pm 0.5$ kV on external I/O	B	EN 61000-4-4: 95
Surge immunity	$\pm 1$ kV differential, $\pm 2$ kV common, AC mains	B	EN 61000-4-5: 95
Conducted RF immunity	150 kHz to 80 MHz, 3 Vrms, 80% AM with 1 kHz sine	A	EN 61000-4-6: 97
Voltage dips, interrupts	0% open, 5 seconds 0% short, 5 seconds 40%, 0.10 seconds 70%, 0.01 seconds	C C C B	EN 61000-4-11: 94

## 2.11 RELIABILITY

### 2.11.1 Annualized Failure Rate (AFR) and Mean Time Between Failures (MTBF)

The product shall achieve an Annualized Failure Rate - AFR - of 0.58%. AFR and MTBF are population statistics that are not relevant to individual units.

AFR and MTBF specifications are based on the following assumptions:

- 8760 power-on-hours per year.
- 250 average power cycles per year.
- Operations at nominal voltages.
- Systems will provide adequate cooling to ensure the case temperatures do not exceed specification.

### 2.11.2 Reliability specifications

Unrecoverable read error rate during	1 LBA per 10 <sup>16</sup> bits read, max
Annualized Failure Rate (AFR) <sup>[5]</sup>	0.58%
Power cycles	25,000 cycles (at nominal voltage and temperature, with 60 cycles per hour and a 50% duty cycle)
Warranty	Warranty terms will vary based on type of warranty chosen: "Managed Life" <sup>[3]</sup> or "Usage Based" <sup>[4]</sup> Consult your Seagate sales representative for warranty terms and conditions.
Preventive maintenance	None required.
Typical Data Retention with Power removed (at 40°C)	3 months <sup>[1]</sup>
Endurance	Method 1: 2 Drive Writes per Day <sup>[2]</sup> Method 2: TBW (per JEDEC JESD218) 400GB = 834TB 200GB = 417TB 100GB = 209TB

[1] As NAND Flash devices age with use, the capability of the media to retain a programmed value begins to deteriorate. This deterioration is affected by the number of times a particular memory cell is programmed and subsequently erased. When a device is new, it has a powered off data retention capability of up to ten years. With use the retention capability of the device is reduced. Temperature also has an effect on how long a Flash component can retain its programmed value with power removed. At high temperature the retention capabilities of the device are reduced. Data retention is not an issue with power applied to the SSD. The SSD drive contains firmware and hardware features that can monitor and refresh memory cells when power is applied.

[2] Endurance is the expected write life of a product when subjected to a specified workload. The drive will support the end user writing the specified multiple of drive user capacity to the drive per day for the expected life of the product. This value is based on randomly writing 4KB transfers aligned on 4KB boundaries across the entire drive LBA range. For example a 200GB drive could be written to up to (n\*200GB) of user data per day for the product life.

[3] Managed Life Warranty: This warranty is term based and includes the Lifetime Endurance Management feature stated in Section 2.4.1.

[4] Usage Based Warranty: This warranty is based on the shorter of term and endurance usage of the drive.

[5] The AFR and MTBF specifications for the drive assumes the operating environment is designed to maintain nominal internal temperature. The rated AFR is based upon a sustained internal temperature of 60°C. Occasional excursions in operating temperature between the rated MTBF temperature and the maximum drive operating temperature may occur without impact to the rated MTBF temperature. However continual or sustained operation at temperatures beyond the rated MTBF temperature will degrade the drive MTBF and reduce product reliability

## 2.12 AGENCY CERTIFICATION

### 2.12.1 Safety certification

These products are certified to meet the requirements of UL60950-1, CSA60950-1 and EN60950 and so marked as to the certify agency.

### 2.12.2 Electromagnetic compatibility

Drives that display the CE mark comply with the European Union (EU) requirements specified in the Electromagnetic Compatibility Directive (2004/108/EC) as put into place 20 July 2007. Testing is performed to the levels specified by the product standards for Information Technology Equipment (ITE). Emission levels are defined by EN 55022, Class B and the immunity levels are defined by EN 55024.

Seagate uses an independent laboratory to confirm compliance with the EC directives specified in the previous paragraph. Drives are tested in representative end-user systems. Although CE-marked Seagate drives comply with the directives when used in the test systems, we cannot guarantee that all systems will comply with the directives. The drive is designed for operation inside a properly designed enclosure, with properly shielded I/O cable (if necessary) and terminators on all unused I/O ports. Computer manufacturers and system integrators should confirm EMC compliance and provide CE marking for their products.

#### Korean KCC

If these drives have the Korean Communications Commission (KCC) logo, they comply with KN22 and KN61000.

#### Australian C-Tick (N176)

If these models have the C-Tick marking, they comply with the Australia/New Zealand Standard AS/NZ CISPR22 and meet the Electromagnetic Compatibility (EMC) Framework requirements of the Australian Communication Authority (ACA).

### 2.12.3 FCC verification

These drives are intended to be contained solely within a personal computer or similar enclosure (not attached as an external device). As such, each drive is considered to be a subassembly even when it is individually marketed to the customer. As a subassembly, no Federal Communications Commission verification or certification of the device is required.

Seagate Technology LLC has tested this device in enclosures as described above to ensure that the total assembly (enclosure, drive, motherboard, power supply, etc.) does comply with the limits for a Class B computing device, pursuant to Subpart J, Part 15 of the FCC rules. Operation with noncertified assemblies is likely to result in interference to radio and television reception.

**Radio and television interference.** This equipment generates and uses radio frequency energy and if not installed and used in strict accordance with the manufacturer's instructions, may cause interference to radio and television reception.

This equipment is designed to provide reasonable protection against such interference in a residential installation. However, there is no guarantee that interference will not occur in a particular installation. If this equipment does cause interference to radio or television, which can be determined by turning the equipment on and off, you are encouraged to try one or more of the following corrective measures:

- Reorient the receiving antenna.
- Move the device to one side or the other of the radio or TV.
- Move the device farther away from the radio or TV.
- Plug the computer into a different outlet so that the receiver and computer are on different branch outlets.

If necessary, you should consult your dealer or an experienced radio/television technician for additional suggestions. You may find helpful the following booklet prepared by the Federal Communications Commission: *How to Identify and Resolve Radio-Television Interference Problems*. This booklet is available from the Superintendent of Documents, U.S. Government Printing Office, Washington, DC 20402. Refer to publication number 004-000-00345-4.

## 2.13 ENVIRONMENTAL PROTECTION

Seagate designs its products to meet environmental protection requirements worldwide, including regulations restricting certain chemical substances.

### 2.13.1 European Union Restriction of Hazardous Substances (RoHS) Directive

The European Union Restriction of Hazardous Substances (RoHS) Directive, restricts the presence of chemical substances, including Lead, Cadmium, Mercury, Hexavalent Chromium, PBB and PBDE, in electronic products, effective July 2006. This drive is manufactured with components and materials that comply with the RoHS Directive.

### 2.13.2 China Restriction of Hazardous Substances (RoHS) Directive 中国限制危险物品的指令

This product has an Environmental Protection Use Period (EPUP) of 20 years. The following table contains information mandated by China's "Marking Requirements for Control of Pollution Caused by Electronic Information Products" Standard.



该产品具有20年的环境保护使用周期（EPUP）。下表包含了中国“电子产品所导致的污染的控制的记号要求”所指定的信息。

Name of Parts 部件名称	Toxic or Hazardous Substances or Elements 有毒有害物质或元素					
	Lead 铅 (Pb)	Mercury 汞 (Hg)	Cadmium 镉 (Cd)	Hexavalent Chromium 六价铬 (Cr6+)	Polybrominated Diphenyl 多溴联苯 (PBB)	Polybrominated Diphenyl Ether 多溴二苯醚 (PBDE)
PCBA	X	O	O	O	O	O
CHASSIS	X	O	O	O	O	O

"O" indicates the hazardous and toxic substance content of the part (at the homogenous material level) is lower than the threshold defined by the China RoHS MCV Standard.

“O”表示该部件（于同类物品程度上）所含的危险和有毒物质低于中国RoHS MCV标准所定义的门槛值。

"X" indicates the hazardous and toxic substance content of the part (at the homogenous material level) is over the threshold defined by the China RoHS MCV Standard.

“X”表示该部件（于同类物品程度上）所含的危险和有毒物质超出中国RoHS MCV标准所定义的门槛值。

## 2.14 CORROSIVE ENVIRONMENT

Seagate electronic drive components pass accelerated corrosion testing equivalent to 10 years exposure to light industrial environments containing sulfurous gases, chlorine and nitric oxide, classes G and H per ASTM B845. However, this accelerated testing cannot duplicate every potential application environment. Users should use caution exposing any electronic components to uncontrolled chemical pollutants and corrosive chemicals as electronic drive component reliability can be affected by the installation environment. The silver, copper, nickel and gold films used in Seagate products are especially sensitive to the presence of sulfide, chloride, and nitrate contaminants. Sulfur is found to be the most damaging. In addition, electronic components should never be exposed to condensing water on the surface of the printed circuit board assembly (PCBA) or exposed to an ambient relative humidity greater than 95%. Materials used in cabinet fabrication, such as vulcanized rubber, that can outgas corrosive compounds should be minimized or eliminated. The useful life of any electronic equipment may be extended by replacing materials near circuitry with sulfide-free alternatives.

## 3.0 CONFIGURING AND MOUNTING THE DRIVE

This section contains the specifications and instructions for configuring and mounting the drive.

### 3.1 HANDLING AND STATIC-DISCHARGE PRECAUTIONS

After unpacking, and before installation, the drive may be exposed to potential handling and electrostatic discharge (ESD) hazards. Observe the following standard handling and static-discharge precautions:

#### Caution:

- Before handling the drive, put on a grounded wrist strap, or ground yourself frequently by touching the metal chassis of a computer that is plugged into a grounded outlet. Wear a grounded wrist strap throughout the entire installation procedure.
- The drive is fragile—handle it with care.
- Always rest the drive on an antistatic surface until you mount it in the computer.
- Do not touch the connector pins or the printed circuit board.
- Do not remove the factory-installed labels from the drive or cover them with additional labels. Removal voids the warranty. Some factory-installed labels contain information needed to service the drive.

### 3.2 CONFIGURING THE DRIVE

Each drive on the Serial ATA interface connects point-to-point with the Serial ATA host adapter. There is no master/slave relationship because each drive is considered a master in a point-to-point relationship. If two drives are attached on one Serial ATA host adapter, the host operating system views the two devices as if they were both “masters” on two separate ports. Both drives behave as if they are Device 0 (master) devices.

Serial ATA drives are designed for easy installation. If you connect the drive and receive a “drive not detected” error, your SATA equipped motherboard or host adapter may use a chipset that does not support SATA 6.0Gb speed autonegotiation. You will need to install a SATA host adapter that supports autonegotiation.

### 3.3 SERIAL ATA CABLES AND CONNECTORS

The Serial ATA interface cable consists of four conductors in two differential pairs, plus three ground connections. The cable size may be 30 to 26 AWG with a maximum length of one meter (39.37 inches). See Table 9 for connector pin definitions. Either end of the SATA signal cable can be attached to the drive or host.

For direct backplane connection, the drive connectors are inserted directly into the host receptacle. The drive and the host receptacle incorporate features that enable the direct connection to be hot pluggable and blind mateable.

For installations which require cables, you can connect the drive as illustrated in Figure 2.

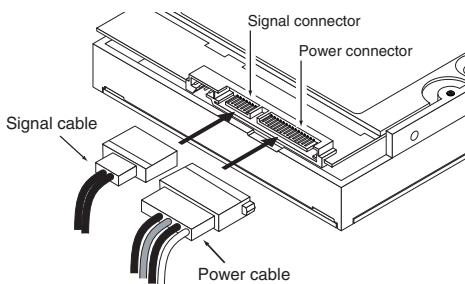

**Figure 2. Attaching SATA cabling**

Each cable is keyed to ensure correct orientation. Seagate 600 Pro SSD drives support latching SATA connectors.

### 3.4 DRIVE MOUNTING

You can mount the drive in any orientation using four screws in the side-mounting holes or four screws in the bottom-mounting holes. Follow these important mounting precautions when mounting the drive:

- Allow a minimum clearance of 0.030 in (0.76 mm) around the entire perimeter of the drive for cooling as a guideline. Please refer to Section 3.5 for final cooling requirements.
- Use only M3 x 0.5 metric mounting screws.
- Four (4) threads (0.080 in) minimum screw engagement recommended. Also ensure maximum screw length does not bottom out in mounting holes.
- Do not overtighten the mounting screws (maximum torque: 4.5 in-lb,  $\pm 0.45$  in-lb).

Refer to Figure 3 for detailed mounting configuration dimensions.

Weight:            7mm models            0.220 pounds            100 grams

**Note.** These dimensions conform to the Small Form Factor Standard documented in SFF-8201 and SFF-8223 found at [www.sffcommittee.org](http://www.sffcommittee.org).

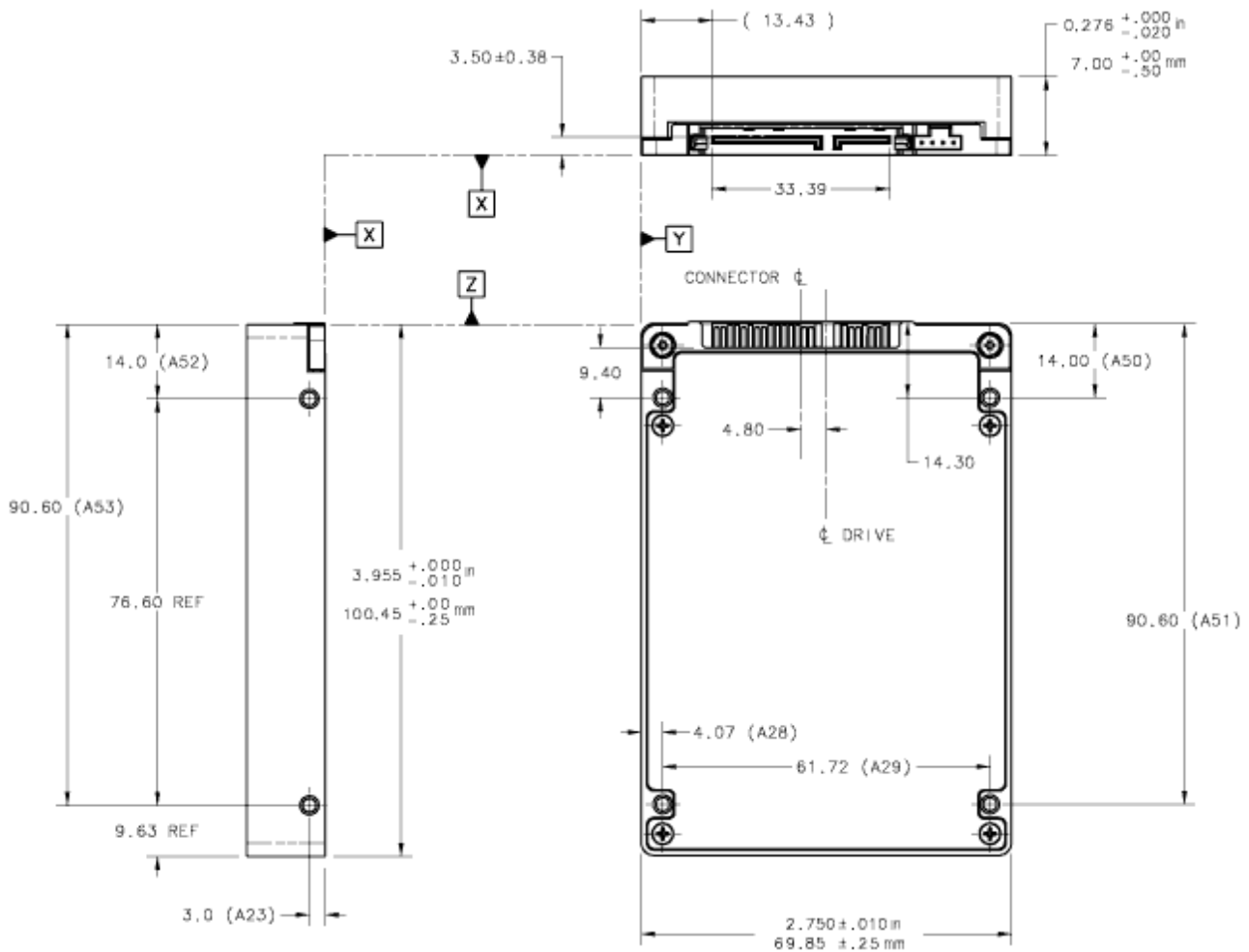

**Figure 3. Mounting configuration dimensions (7mm models)**



### 3.5 COOLING

Cabinet cooling must be designed by the customer so that the ambient temperature immediately surrounding the drive will not exceed temperature conditions specified in Section 2.9.1, "Temperature."

The rack, cabinet, or drawer environment for the drive must provide heat removal. You should confirm that adequate heat removal is provided using the temperature measurement guidelines described in Section 2.9.1.

Forced air flow may be required to keep temperatures at or below the temperatures specified in Section 2.9.1 in which case the drive should be oriented, or air flow directed, so that the least amount of air flow resistance is created while providing air flow to the drive. Also, the shortest possible path between the air inlet and exit should be chosen to minimize the travel length of air heated by the drive and other heat sources within the rack, cabinet, or drawer environment.

If forced air is determined to be necessary, possible air-flow patterns are shown in Figure 4. The air-flow patterns are created by one or more fans, either forcing or drawing air as shown in the illustrations. Conduction, convection, or other forced air-flow patterns are acceptable as long as the temperature measurement guidelines of Section 2.9.1 are met.

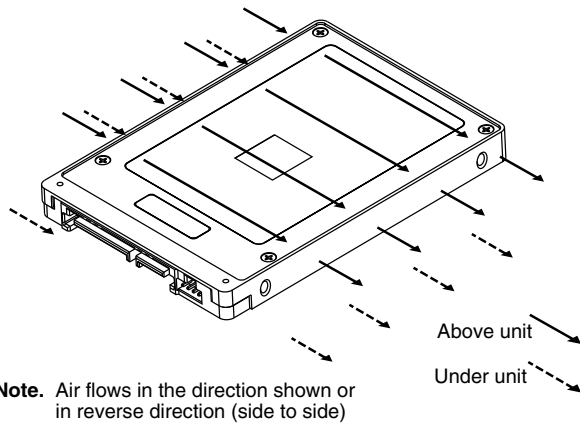
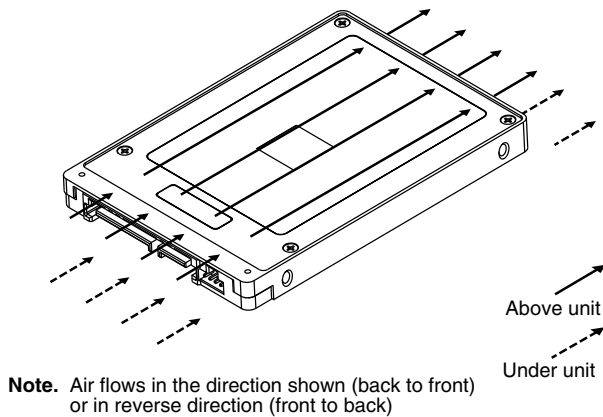

**Figure 4. Air flow**

Image may not represent actual product, for reference only.

## 4.0 SERIAL ATA (SATA) INTERFACE

These drives use the industry-standard Serial ATA interface that supports FIS data transfers. It supports ATA programmed input/output (PIO) modes 0–4; multiword DMA modes 0–2, and Ultra DMA modes 0–6.

For detailed information about the Serial ATA interface, refer to the “Serial ATA: High Speed Serialized AT Attachment” specification.

### 4.1 HOT-PLUG COMPATIBILITY

Seagate 600 Pro SSD drives incorporate connectors which enable you to hot plug these drives in accordance with the Serial ATA II: Extension to Serial ATA 1.0a specification. This specification can be downloaded from [www.serialata.org](http://www.serialata.org).

### 4.2 SERIAL ATA DEVICE PLUG CONNECTOR PIN DEFINITIONS

Table 9 summarizes the 2.5” drive Signal and Power SATA Plug.

**Table 9 2.5” SATA Connector Plug Pinout**

Segment	Pin	Function	Definition
Signal	S1	GND	Ground
	S2	A+	Differential Signal Pair (Host to Drive)
	S3	A-	
	S4	GND	Ground
	S5	B-	Differential Signal Pair (Drive to Host)
	S6	B+	
	S7	GND	Ground
Key and spacing separate signal and power segments			
Power	P1	V <sub>33</sub>	Unused [2]
	P2	V <sub>33</sub>	
	P3	V <sub>33</sub>	
	P4	GND	Ground [1]
	P5	GND	
	P6	GND	
	P7	V <sub>5</sub>	5V power to Drive
	P8	V <sub>5</sub>	
	P9	V <sub>5</sub>	
	P10	Ground	Ground
	P11	LED Signal	Activity LED: Driven low to light
	P12	Ground	Ground [1]
	P13	V <sub>12</sub>	Unused [3]
	P14	V <sub>12</sub>	
	P15	V <sub>12</sub>	

#### Notes:

[1] Ground pins 4 and 12 mate first on SATA backplane connectors.

[2] The three V<sub>33</sub> pins are unused but connected together on the drive. They can be used for a drive-in-place detection.

[3] The three V<sub>12</sub> pins are unused but connected together on the drive. They can be used for a drive-in-place detection.

Table 10 summarizes the 1.8" drive Signal and Power SATA Plug.

**Table 10 1.8" SATA Connector Plug Pinout**

Segment	Pin	Function	Definition
<b>Signal</b>	S1	GND	Ground
	S2	A+	Differential Signal Pair (Host to Drive)
	S3	A-	
	S4	GND	Ground
	S5	B-	Differential Signal Pair (Drive to Host)
	S6	B+	
	S7	GND	Ground
Spacing separates signal and power segments			
<b>Power</b>	P1	V <sub>33</sub>	Unused [2]
	P2	V <sub>33</sub>	
	P3	GND	Ground [1]
	P4	GND	
	P5	V <sub>5</sub>	5V power to Drive
	P6	V <sub>5</sub>	
	P7	LED Signal	Activity LED: Driven low to light
	Key	Key	Keyway
	P8	Optional	Reserved for Seagate use. Leave unconnected.
	P9	Optional	

**Notes:**

[1] Ground pins 3 and 4 mate first on micro SATA backplane connectors

[2] The two V<sub>33</sub> pins are unused but connected together on the drive. They can be used for a drive-in-place detection.

### 4.3 SUPPORTED ATA COMMANDS

The following table lists Serial ATA standard commands that the drive supports. For a detailed description of the ATA commands, refer to the Serial ATA: High Speed Serialized AT Attachment specification. See “S.M.A.R.T. commands” on page 33 for details and subcommands used in the S.M.A.R.T. implementation.

**Table 11 Supported ATA commands**

<b>COMMAND NAME</b>	<b>COMMAND CODE (IN HEX)</b>
Check Power Mode	E5 <sub>H</sub>
Data Set Management with Trim Support	06 <sub>H</sub>
Download Microcode	92 <sub>H</sub>
Flush Cache	E7 <sub>H</sub>
Flush Cache Extended	EA <sub>H</sub>
Identify Device	EC <sub>H</sub>
Idle	E3 <sub>H</sub>
Idle Immediate	E1 <sub>H</sub>
Initialize Device Parameters	91 <sub>H</sub>
NOP	00 <sub>H</sub>
Read Buffer	E4 <sub>H</sub>
Read DMA	C8 <sub>H</sub>
Read DMA Extended	25 <sub>H</sub>
Read FPDMA Queued	60 <sub>H</sub>
Read Log Ext	2F <sub>H</sub>
Read Multiple	C4 <sub>H</sub>
Read Multiple Extended	29 <sub>H</sub>
Read Native Max Address	F8 <sub>H</sub>
Read Native Max Address Extended	27 <sub>H</sub>
Read Sectors	20 <sub>H</sub>
Read Sectors Extended	24 <sub>H</sub>
Read Verify Sectors	40 <sub>H</sub>
Read Verify Sectors Extended	42 <sub>H</sub>
Sanitize Block Erase	B4 <sub>H</sub> /0012 <sub>H</sub>
Sanitize Freeze Lock Ext	B4 <sub>H</sub> /0020 <sub>H</sub>
Sanitize Status Ext	B4 <sub>H</sub> /0000 <sub>H</sub>
Security Disable Password	F6 <sub>H</sub>
Security Erase Prepare	F3 <sub>H</sub>
Security Erase Unit	F4 <sub>H</sub>
Security Freeze	F5 <sub>H</sub>
Security Set Password	F1 <sub>H</sub>
Security Unlock	F2 <sub>H</sub>
Set Features	EF <sub>H</sub>
Set Max Address	F9 <sub>H</sub>
Set Max Address Extended	37 <sub>H</sub>

<b>COMMAND NAME</b>	<b>COMMAND CODE (IN HEX)</b>
Set Multiple Mode	C6 <sub>H</sub>
Sleep	E6 <sub>H</sub>
S.M.A.R.T. Disable Operations	B0 <sub>H</sub> / D9 <sub>H</sub>
S.M.A.R.T. Enable Operations	B0 <sub>H</sub> / D8 <sub>H</sub>
S.M.A.R.T. Execute Offline	B0 <sub>H</sub> / D4 <sub>H</sub>
S.M.A.R.T. Read Data	B0 <sub>H</sub> / D0 <sub>H</sub>
S.M.A.R.T. Read Log Sector	B0 <sub>H</sub> / D5 <sub>H</sub>
S.M.A.R.T. Return Status	B0 <sub>H</sub> / DA <sub>H</sub>
S.M.A.R.T. Write Log Sector	B0 <sub>H</sub> / D6 <sub>H</sub>
Standby	E2 <sub>H</sub>
Standby Immediate	E0 <sub>H</sub>
Write Buffer	E8 <sub>H</sub>
Write DMA	CA <sub>H</sub>
Write DMA Extended	35 <sub>H</sub>
Write DMA FUA Extended	3D <sub>H</sub>
Write FPDMA Queued	61 <sub>H</sub>
Write Log Extended	3F <sub>H</sub>
Write Multiple	C5 <sub>H</sub>
Write Multiple Extended	39 <sub>H</sub>
Write Multiple FUA Extended	CE <sub>H</sub>
Write Sectors	30 <sub>H</sub>
Write Sectors Extended	34 <sub>H</sub>
Write Uncorrectable Extended	45 <sub>H</sub>

### 4.3.1 Identify Device command

The Identify Device command (command code EC<sub>H</sub>) transfers information about the drive to the host following power up. The data is organized as a single 512-byte block of data, whose contents are shown in Table 11 on page 24. All reserved bits or words should be set to zero. Parameters listed with an “x” are drive-specific or vary with the state of the drive. see Section 2.0 on page 3 for default parameter settings.

The following commands contain drive-specific features that may not be included in the Serial ATA specification.

WORD	DESCRIPTION	VALUE
0	General configuration	0C5A <sub>H</sub>
1	Number of logical cylinders (obsolete) 16,383	3FFF <sub>H</sub>
2	Specific configuration	C837 <sub>H</sub>
3	Number of logical heads (obsolete) 16	0010 <sub>H</sub>
4-5	Retired	0000 <sub>H</sub>
6	Number of logical sectors per logical track (obsolete) 63	003F <sub>H</sub>
7-8	Reserved for CompactFlash Association	0000 <sub>H</sub>
9	Retired	0000 <sub>H</sub>
10-19	Serial number: (ATA ASCII string padded with spaces (20 <sub>H</sub> ))	ASCII
20-21	Retired	0000 <sub>H</sub>
22	Obsolete	0004 <sub>H</sub>
23-26	Firmware revision (ATA ASCII string padded with spaces (20h))	ASCII
27-46	Model number (ATA ASCII string padded with spaces (20h))	ASCII
47	(Bits 7-0) Maximum number of logical sectors that shall be transferred per DRQ data block on READ/WRITE MULTIPLE commands. 16	8010 <sub>H</sub>
48	Reserved for Trusted Computing feature set options	4000 <sub>H</sub>
49	Capabilities – Standby Timer, IORDY Support, etc	2F00 <sub>H</sub>
50	Capabilities Continued	4000 <sub>H</sub>
51	PIO data transfer cycle timing option (Obsolete)	0200 <sub>H</sub>
52	Retired	0200 <sub>H</sub>
53	Words 54-58, 64-70 and 88 are valid	0006 <sub>H</sub>
54	Number of current logical cylinders (Obsolete)	3FFF <sub>H</sub>
55	Number of current logical heads (Obsolete)	0010 <sub>H</sub>
56	Number of current logical sectors per logical track (Obsolete)	003F <sub>H</sub>
57-58	Current capacity in sectors (Obsolete)	FC10 <sub>H</sub> 00FB <sub>H</sub>
59	Number of LBAs transferred per Read Multiple or Write Multiple. Sanitize Command Support	0010 <sub>H</sub>
60-61	Total number of user addressable logical sectors for 28-bit commands Note: The maximum value allowed in this field is: 0FFFFFFFh. If this field contains 0FFFFFFFh and the device has user addressable LBAs greater than or 137GB, then words 100..103 contain the total number of user addressable LBAs	XXXXXXXX <sub>H</sub> *
62	Obsolete	0000 <sub>H</sub>
63	Multiword DMA active and modes supported (see note following this table)	0407 <sub>H</sub>
64	Advanced PIO modes supported. SATA = 0003h	0003 <sub>H</sub>
65	Minimum Multiword DMA transfer cycle time per word (120ns)	0078 <sub>H</sub>
66	Recommended Multiword DMA transfer cycle time (120ns)	0078 <sub>H</sub>

WORD	DESCRIPTION	VALUE
67	Minimum PIO transfer cycle time without flow control (120ns)	0078 <sub>H</sub>
68	Minimum PIO transfer cycle time with IORDY flow control (120ns)	0078 <sub>H</sub>
69	Additional Features and Commands supported. Trim Features supported, DMA commands supported	5D20 <sub>H</sub>
70	Reserved	0000 <sub>H</sub>
71–74	Reserved for ATAPI	0000 <sub>H</sub>
75	Queue depth	001F <sub>H</sub>
76	Serial ATA Capabilities Supported	850E <sub>H</sub>
77	Reserved for Serial ATA	0004 <sub>H</sub>
78	Serial ATA features supported	0048 <sub>H</sub>
79	Serial ATA features enabled	0040 <sub>H</sub>
80	Major version number	01F0 <sub>H</sub>
81	Minor version number	0029 <sub>H</sub>
82	Commands and feature sets supported	346B <sub>H</sub>
83	Commands and feature sets supported	7509 <sub>H</sub>
84	Commands and feature sets supported	4163 <sub>H</sub>
85	Commands and feature sets supported or enabled	3469 <sub>H</sub>
86	Commands and feature sets supported or enabled	BC01 <sub>H</sub>
87	Commands and feature sets supported or enabled	4163 <sub>H</sub>
88	Ultra DMA support and current mode (see note following this table)	007F <sub>H</sub>
89	Security erase time	0003 <sub>H</sub>
90	Enhanced security erase time	0003 <sub>H</sub>
91	Current APM level value	FFFE <sub>H</sub>
92	Master password Identifier	0000 <sub>H</sub>
93	Hardware reset result	0000 <sub>H</sub>
94	Reserved	FE00 <sub>H</sub>
95–99	ATA-reserved	0000 <sub>H</sub>
100–103	Total Number of User Addressable Logical Blocks for 48-bit commands. These words are required for drives that support the 48-bit addressing feature. Maximum value: 0000FFFFFFFFFh	480GB model = 937,703,088 400GB model = 781,422,768 240GB model = 468,862,128 200GB model = 390,721,968 120GB model = 234,441,648 100GB model = 195,371,568
104	Reserved for Streaming Command Set	0000 <sub>H</sub>
105	Maximum number of 512-byte blocks of LBA Range Entries (see 4.18.3.2) per DATA SET MANAGEMENT command	0001 <sub>H</sub>
106	Physical sector size / logical sector size	6004 <sub>H</sub>
107	Inter-seek delay for ISO 7779 standard acoustic testing	0000 <sub>H</sub>
108–111	World wide name	XXXX <sub>H</sub>
112–115	Reserved	0000 <sub>H</sub>
116	Reserved for TLC	0000 <sub>H</sub>
117–118	Logical sector size (DWord)	0000 <sub>H</sub>
119	Commands and feature sets supported	401C <sub>H</sub>

WORD	DESCRIPTION	VALUE
120	Commands and feature sets supported or enabled	401C <sub>H</sub>
121–126	Reserved for expanded supported and enabled settings	0000 <sub>H</sub>
127	Obsolete	0000 <sub>H</sub>
128	Security status	0021 <sub>H</sub>
129–159	Vendor specific	xxxx <sub>H</sub>
160–167	Reserved for the CompactFlash Association	0000 <sub>H</sub>
168	Device Nominal Form Factor	0003 <sub>H</sub>
169	DATA SET MANAGEMENT features supported	0001 <sub>H</sub>
170–173	Additional Product Identifier (ATA String)	0000 <sub>H</sub>
174–175	Reserved	0000 <sub>H</sub>
176–205	Reserved	0000 <sub>H</sub>
206	SCT Command Transport	0000 <sub>H</sub>
207–208	Reserved for CE-ATA	0000 <sub>H</sub>
209	Alignment of logical blocks within a physical block	4000 <sub>H</sub>
210–211	Write-Read-Verify Sector Count Mode 3	0000 <sub>H</sub>
212–213	Write-Read-Verify Sector Count Mode 2 (DWord)	0000 <sub>H</sub>
214	NV Cache Capability	0000 <sub>H</sub>
215-216	NV Cache Size in Logical Blocks (DWord)	0000 <sub>H</sub>
217	Nominal media rotation rate	0001 <sub>H</sub>
218	Reserved	0000 <sub>H</sub>
219	NV Cache Options	0000 <sub>H</sub>
220	Write-Read-Verify feature set	0000 <sub>H</sub>
221	Reserved	0000 <sub>H</sub>
222	Transport major version number	1020 <sub>H</sub>
223	Transport minor version number	0000 <sub>H</sub>
224-233	Reserved	0000 <sub>H</sub>
234	Minimum number of 512-byte data blocks per DOWNLOAD MICROCODE command for mode 03h	0000 <sub>H</sub>
235	Maximum number of 512-byte data blocks per DOWNLOAD MICROCODE command for mode 03h	0000 <sub>H</sub>
236-254	Reserved	0000 <sub>H</sub>
255	Integrity word (XXA5 <sub>H</sub> )	xxA5 <sub>H</sub>

**Note.** See the bit descriptions below for words 49, 69, 76, 78, 82-87 and 119-120 of the Identify Drive data.

Description (if bit is set to 1)		
	Bit	Word 49
	8	DMA Supported
	9	Shall be set to 1
	10	IORDY May be disabled
	11	IORDY supported
	13	Standby Timer Values supported
	Bit	Word 50
	14	Shall be set to 1



Bit	Word 69
5	Read zero after Trim is supported
6	Optional ATA 28-bit commands supported
8	Download Microcode DMA supported
9	Set Max Password DMA and Set Max Unlock DMA supported
10	Write Buffer DMA Supported
11	Read Buffer DMA Supported
12	DEVICE CONFIGURATION IDENTIFY DMA and DEVICE CONFIGURATION SET DMA are supported
13	Long Physical Sector Alignment Error Reporting Control is supported
14	Deterministic read after Trim is supported
Bit	Word 76
0	Shall be cleared to zero
1	Supports SATA Gen1 Signaling Speed (1.5Gb/s)
2	Supports SATA Gen2 Signaling Speed (3.0Gb/s)
3	Supports SATA Gen3 Signaling Speed (6.0Gb/s)
4-7	Reserved for Serial ATA
8	Supports the NCQ feature set
9	Supports receipt of host initiated power management requests
10	Supports Phy Event Counters
11	Supports Unload while NCQ commands are outstanding
12	Supports NCQ priority information
13-15	Reserved for Serial ATA
Bit	Word 78
0	Shall be cleared to zero
1	Device supports non-zero buffer offsets
2	Device supports DMA Setup auto-activation
3	Device supports initiating power management
4	Device supports in-order data delivery
5	Reserved for Serial ATA
6	Device supports Software Settings Preservation
7-15	Reserved for Serial ATA
Bit	Word 82
0	The SMART feature set is supported
1	The Security feature set is supported
2	Obsolete
3	Mandatory Power Management feature set is supported
4	PACKET feature set is supported
5	Volatile write cache is supported
6	Read look-ahead is supported
7	Release interrupt is supported
8	SERVICE interrupt is supported
9	DEVICE RESET command is supported
10	HPA feature set is supported
11	Obsolete
12	WRITE BUFFER command is supported
13	READ BUFFER command is supported
14	NOP command is supported
15	Obsolete

Bit	Word 83
0	DOWNLOAD MICROCODE command is supported
1	Obsolete
2	CFA feature set is supported
3	APM feature set is supported
4	Obsolete
5	PUIS feature set is supported
6	SET FEATURES subcommand is required to spin-up after power-up
7	Reserved
8	SET MAX security extension is supported
9	AAM feature set is supported
10	48-bit Address feature set is supported
11	DCO feature set is supported
12	Mandatory FLUSH CACHE command is supported
13	FLUSH CACHE EXT command is supported
14	Shall be set to one
15	Shall be cleared to zero
Bit	Word 84
0	SMART error logging is supported
1	SMART self-test is supported
2	Media serial number is supported
3	Media Card Pass Through Command feature set is supported
4	Streaming feature set is supported
5	GPL feature set is supported
6	WRITE DMA FUA EXT and WRITE MULTIPLE FUA EXT commands are supported
7	Obsolete
8	64-bit World wide name is supported
9-10	Obsolete
11-12	Reserved for TLC
13	IDLE IMMEDIATE command with UNLOAD feature is supported
14	Shall be set to one
15	Shall be cleared to zero
Bit	Word 85
9	DEVICE RESET command is not supported
10	HPA feature set is supported
11	Obsolete
12	WRITE BUFFER command is supported
13	READ BUFFER command is supported
14	NOP command is supported
15	Obsolete
Bit	Word 86
0	DOWNLOAD MICROCODE command is supported
1	Obsolete
2	CFA feature set is supported
6	SET FEATURES subcommand is required to spin-up after power-up
10	The 48-bit Address features set is supported
11	The DCO feature set is supported
12	FLUSH CACHE command supported
13	FLUSH CACHE EXT command supported
15	Words 119 ...120 are valid

<b>Bit</b>	<b>Word 87</b>
0	SMART error logging is supported
1	SMART self-test supported
3	The Media Card Pass Through Command feature set is supported
5	The GPL feature set is supported
6	WRITE DMA FUA EXT and WRITE MULTIPLE FUA EXT commands are supported
8	The 64-bit World wide name is supported
13	The IDLE IMMEDIATE command with UNLOAD FEATURE is supported
14	Shall be set to one
15	Shall be cleared to zero
<b>Bit</b>	<b>Word 119</b>
0	Reserved
1	Write-Read-Verify feature set is supported
2	WRITE UNCORRECTABLE EXT command is supported
3	READ LOG DMA EXT and WRITE LOG DMA EXT commands are supported
4	DOWNLOAD MICROCODE command with mode 3 is supported
5	Free-fall Control feature set is supported
6	Extended Status Reporting feature set is supported
7	Extended Power Conditions feature set is supported
8-13	Reserved
14	Shall be set to one
15	Shall be cleared to zero
<b>Bit</b>	<b>Word 120</b>
2	WRITE UNCORRECTABLE EXT command is supported
3	READ LOG DMA EXT and WRITE LOG DMA EXT commands are supported
4	DOWNLOAD MICROCODE command with mode 3 is supported
14	Shall be set to one
15	Shall be cleared to zero

### 4.3.2 Set Features command

This command controls the implementation of various features that the drive supports. When the drive receives this command, it sets BSY, checks the contents of the Features register, clears BSY and generates an interrupt. If the value in the register does not represent a feature that the drive supports, the command is aborted. Power-on default has the read look-ahead and write caching features enabled. The acceptable values for the Features register are defined as follows:

**Table 12 Set Features command values**

02 <sub>H</sub>	Enable write cache ( <i>default</i> ).
03 <sub>H</sub>	Set transfer mode (based on value in Sector Count register). Sector Count register values:
00 <sub>H</sub>	Set PIO mode to default (PIO mode 2).
01 <sub>H</sub>	Set PIO mode to default and disable IORDY (PIO mode 2).
08 <sub>H</sub>	PIO mode 0
09 <sub>H</sub>	PIO mode 1
0A <sub>H</sub>	PIO mode 2
0B <sub>H</sub>	PIO mode 3
0C <sub>H</sub>	PIO mode 4 ( <i>default</i> )
20 <sub>H</sub>	Multiword DMA mode 0
21 <sub>H</sub>	Multiword DMA mode 1
22 <sub>H</sub>	Multiword DMA mode 2
40 <sub>H</sub>	Ultra DMA mode 0
41 <sub>H</sub>	Ultra DMA mode 1
42 <sub>H</sub>	Ultra DMA mode 2
43 <sub>H</sub>	Ultra DMA mode 3
44 <sub>H</sub>	Ultra DMA mode 4
45 <sub>H</sub>	Ultra DMA mode 5
46 <sub>H</sub>	Ultra DMA mode 6
10 <sub>H</sub>	Enable use of SATA features
02 <sub>H</sub>	DMA Setup FIS Auto-Activate optimization
03 <sub>H</sub>	Device-initiated interface power state transitions
06 <sub>H</sub>	Software Settings Preservation
55 <sub>H</sub>	Disable read look-ahead (read cache) feature
66 <sub>H</sub>	Disable reverting to power-on defaults
82 <sub>H</sub>	Disable write cache
90 <sub>H</sub>	Disable use of SATA features
02 <sub>H</sub>	DMA Setup FIS Auto-Activate optimization
03 <sub>H</sub>	Device-initiated interface power state transitions
06 <sub>H</sub>	Software Settings Preservation
AA <sub>H</sub>	Enable read look-ahead (read cache) feature ( <i>default</i> ).
CC <sub>H</sub>	Enable reverting to power-on defaults

**Note.** At power-on, or after a hardware or software reset, the default values of the features are as indicated above.

### 4.3.3 S.M.A.R.T. commands

S.M.A.R.T. provides near-term failure prediction for drives. When S.M.A.R.T. is enabled, the drive monitors predetermined drive attributes that are susceptible to degradation over time. If self-monitoring determines that a failure is likely, S.M.A.R.T. makes a status report available to the host. Not all failures are predictable. S.M.A.R.T. predictability is limited to the attributes the drive can monitor. For more information on S.M.A.R.T. commands and implementation, see the *Draft ATA-8 Standard*.

SeaTools diagnostic software activates a built-in drive self-test (DST S.M.A.R.T. command for D4<sub>H</sub>) that eliminates unnecessary drive returns. The diagnostic software ships with all new drives and is also available at: <http://www.seagate.com/support/downloads/seatools/>.

This drive is shipped with S.M.A.R.T. features disabled. You must have a recent BIOS or software package that supports S.M.A.R.T. to enable this feature. The table below shows the S.M.A.R.T. command codes that the drive uses.

**Table 13 S.M.A.R.T. commands**

CODE IN FEATURES REGISTER	S.M.A.R.T. COMMAND
D0 <sub>H</sub>	S.M.A.R.T. Read Data
D4 <sub>H</sub>	S.M.A.R.T. Execute Off-line Immediate (runs DST)
D5 <sub>H</sub>	S.M.A.R.T. Read Log Sector
D6 <sub>H</sub>	S.M.A.R.T. Write Log Sector
D8 <sub>H</sub>	S.M.A.R.T. Enable Operations
D9 <sub>H</sub>	S.M.A.R.T. Disable Operations
DA <sub>H</sub>	S.M.A.R.T. Return Status

**Note.** If an appropriate code is not written to the Features Register, the command is aborted and 0x04 (abort) is written to the Error register.

### 4.3.4 SSD Percentage Endurance Remaining Indicator

An application can interrogate the drive through the host to determine an estimate of the percentage of device life that is remaining. Seagate SeaTools diagnostic software has the capability to report the indicator value.

**A**

ACA 17  
acceleration 15  
Access time 6  
Agency certification 17  
air flow  
    illustrated 21  
altitude 14  
ambient temperature 6, 7  
Annualized Failure Rate (AFR) 16  
ATA commands 24  
Australia/New Zealand Standard AS/NZ CISPR22 17  
Australian Communication Authority (ACA) 17  
Australian C-Tick 17  
Average seek time 6

**C**

cables and connectors 19  
capacity 4  
CE mark 17  
certification 17  
Check Power Mode 24  
China RoHS directive 18  
Class B computing device 17  
compatibility 17  
Conducted RF immunity 15  
Configuring the drive 19  
connectors 19  
Corrosive environment 18  
CSA60950-1 17  
cycles 16  
Cylinders 4

**D**

Data Set Management with Trim Support 24  
data-transfer rates 2  
DC power 7  
Default logical geometry 4  
dimensions 20  
Download Microcode 24

**E**

Electrical fast transient 15  
Electromagnetic compatibility 17  
Electromagnetic Compatibility Directive (2004/108/EC) 17  
Electromagnetic immunity 15  
Electrostatic discharge 15  
electrostatic discharge (ESD) 19  
EN 55022, Class B 17  
EN 55024 17  
EN60950 17  
Environmental specifications 14  
ESD 19  
EU 17  
EU RoHS directive 18

European Union (EU) requirements 17

**F**

FCC verification 17  
features 2  
Federal Communications Commission 17  
Flush Cache 24  
Flush Cache Extended 24  
Formatted capacity 4

**G**

geometry 4  
Gs 15  
guaranteed LBAs 4

**H**

Handling precautions 19  
heads 4  
height 6  
humidity 14

**I**

Identify Device 24  
Identify Device command 26  
Idle 24  
Idle Immediate 24  
Idle mode 7  
Idle mode power 7  
Information Technology Equipment (ITE) 17  
Initialize Device Parameters 24  
interface 5, 22  
Interface technology 5  
is 6  
ITE 17

**K**

KCC 17  
Korean Communications Commission 17  
Korean RRL 17

**L**

LBA mode 4  
length 6  
logical geometry 4

**M**

maintenance 16  
Managed Life Warranty 16  
master/slave 2  
maximum temperature 14  
mounting 20  
mounting configuration 20  
mounting configuration dimensions 20  
mounting screws 14

mounting the drive 19

## N

nominal power 6  
 Nonoperating shock 14  
 Nonoperating vibration 15  
 NOP 24

## O

Operating shock 14  
 Operating vibration 15

## P

Page-to-page access 6  
 page-to-page accesses 6  
 Peak operating mode 7  
 Performance 5  
 Physical characteristics 6  
 point-to-point 2, 19  
 Power consumption 7  
 Power specifications 7  
 precautions 19  
 printed circuit board 19

## Q

quick reference 3

## R

Radiated RF immunity 15  
 Radio and television interference 17  
 radio frequency (RF) 15  
 Read Buffer 24  
 Read DMA 24  
 Read DMA Extended 24  
 Read FPDMA queued 24  
 Read Log Ext 24  
 Read Multiple 24  
 Read Multiple Extended 24  
 Read Native Max Address 24  
 Read Native Max Address Extended 24  
 Read Sectors 24  
 Read Sectors Extended 24  
 Read Verify Sectors 24  
 Read Verify Sectors Extended 24  
 Read/write heads 4  
 Recording technology 5  
 relative humidity 14  
 Reliability 16  
 RF 15  
 RoHS 18

## S

S.M.A.R.T. Disable Operations 25  
 S.M.A.R.T. Enable Operations 25

S.M.A.R.T. Execute Offline 25  
 S.M.A.R.T. implementation 24  
 S.M.A.R.T. Read Data 25  
 S.M.A.R.T. Read Log Sector 25  
 S.M.A.R.T. Return Status 25  
 S.M.A.R.T. Write Log sector 25  
 Safety certification 17  
 Sanitize Block Erase 24  
 Sanitize Freeze Lock Ext 24  
 Sanitize Status Ext 24  
 SATA 22  
 screws 14  
 Seagate Technology Support Services 1  
 Sectors per track 4  
 Security Disable Password 24  
 Security Erase Prepare 24  
 Security Erase Unit 24  
 Security Freeze 24  
 Security Set Password 24  
 Security Unlock 24  
 Serial ATA (SATA) interface 22  
 serial ATA ports 2  
 Set Features 24  
 Set Max Address 24  
 Set Max Address Extended 24  
 Set Multiple Mode 25  
 Shock 14  
 Signal and Power SATA Plug and Nominal Mate Sequence  
     22, 23  
 Sleep 25  
 Specification summary table 3  
 SSD Percentage Endurance Remaining Indicator 33  
 Standby 25  
 Standby Immediate 25  
 Standby mode 7  
 Startup power 7  
 static-discharge 19  
 Surge immunity 15

## T

temperature 6, 14  
 temperature gradient 14  
 Time to Ready 6

## U

UL60950-1 17  
 Usage Based Warranty 16

## V

Vibration 14  
 Voltage dips, interrupts 15

## W

weight 6  
 wet bulb temperature 14

width 6  
Write Buffer 25  
Write DMA 25  
Write DMA Extended 25  
Write DMA FUA Extended 25  
Write FPDMA queued 25  
Write Log Extended 25  
Write Multiple 25  
Write Multiple Extended 25  
Write Multiple FUA Extended 25  
Write Sectors 25  
Write Sectors Extended 25  
write uncorrectable 25





**Seagate Technology LLC**

*AMERICAS Seagate Technology LLC 10200 South De Anza Boulevard, Cupertino, California 95014, United States, 408-658-1000*

*ASIA/PACIFIC Seagate Singapore International Headquarters Pte. Ltd. 7000 Ang Mo Kio Avenue 5, Singapore 569877, 65-6485-3888*

*EUROPE, MIDDLE EAST AND AFRICA Seagate Technology SAS 16-18 rue du Dôme, 92100 Boulogne-Billancourt, France, 33 1-4186 10 00*

*Publication Number: 100717897, Rev. A*

*March 2013*